

# On a small gain theorem for ISS networks in dissipative Lyapunov form\*

Sergey Dashkovskiy, Hiroshi Ito and Fabian Wirth<sup>‡</sup>

September 29, 2010

## Abstract

In this paper we consider the stability of networks consisting of nonlinear ISS systems supplied with ISS Lyapunov functions defined in dissipative form. The problem of constructing an ISS Lyapunov function for the network is addressed. Our aim is to provide a geometrical condition of a small gain type under which this construction is possible and to describe a method of an explicit construction of such an ISS Lyapunov function. In the dissipative form, the geometrical approach allows us to discuss both Lipschitz continuous construction and continuously differentiable construction of ISS Lyapunov functions.

## 1 INTRODUCTION

Interconnections of nonlinear systems appear in many applications such as logistic problems, biologic systems, power networks and others. Stability analysis of these systems is an important issue for their performance and control. Such interconnections can be studied in different frameworks such as passivity, dissipativity [24, 8, 17, 20], input-to-state stability (ISS) [21] and others. Since we consider systems with inputs we will use the notion of ISS for our purposes. There are several equivalent ways to define this property. Originally in [21] it was defined in terms of a bound for the trajectories of a system, where the bound depends on the initial condition and the input function. This property can be equivalently stated in terms of an ISS-Lyapunov function. The latter formulation can again be defined in two essentially equivalent ways: in the so-called implication form and with the help of a dissipation inequality and a supply rate, see [22] for details and discussions of the different ISS formulations. In

---

\*S. Dashkovskiy is supported by the German Research Foundation (DFG) as part of the Collaborative Research Center 637 “Autonomous Cooperating Logistic Processes”. H.Ito is supported in part by Grant-in-Aid for Scientific Research of JSPS under grant 19560446. F. Wirth is supported by Volkswagen-Stiftung under grant I/82683-684.

<sup>†</sup>S. Dashkovskiy is with the Department of Mathematics and Computer Science, University of Bremen, Germany [dsn@math.uni-bremen.de](mailto:dsn@math.uni-bremen.de)

<sup>‡</sup>H. Ito is with the Department of Systems Design and Informatics, Kyushu Institute of Technology, Japan [hiroshi@ces.kyutech.ac.jp](mailto:hiroshi@ces.kyutech.ac.jp)

<sup>§</sup>F. Wirth is with the Institute of Mathematics, University of Würzburg, Germany [wirth@mathematik.uni-wuerzburg.de](mailto:wirth@mathematik.uni-wuerzburg.de)

<sup>¶</sup>\* A preliminary version of this paper was presented at the European Conference on Control 2009 in Budapest, Hungary

this paper we concentrate on the dissipative ISS formulation. Our aim is to derive a small gain result for general interconnected systems in this framework. This complements recent results in [5, 7], where small gain results have been achieved in the trajectory formulation as well as for the implication form of the ISS Lyapunov formulation.

The ISS property of the interconnections of two ISS systems was considered in the pioneering papers [14] and [13]. In [14] the ISS estimates for the trajectories of subsystems were used to prove the ISS property for the interconnection provided a small gain condition is satisfied. A Lyapunov version of this result was given in [13] where the Lyapunov functions were defined in the so called implication form. These results were recently extended to the case of interconnections of  $n$  systems, see [5, 7, 15, 6, 16]. A small gain theorem for two systems with ISS-Lyapunov functions satisfying the dissipation inequality was obtained in [9]. It is worth noting that this definition has the advantage that it unifies the definition of ISS and integral ISS (iISS) systems. The latter set of systems is larger and contains the ISS systems as a subset. The small gain theorem for two iISS systems was proved in [10, 12]. Moreover the construction of the corresponding Lyapunov function is given in a smooth way in contrast to the constructions given in [13] and [7, 6]. An alternative way to treat iISS systems using cooperative monotone systems is pursued in [19].

In this paper, we consider a network consisting of  $n$  ISS systems with given ISS-Lyapunov functions defined by dissipation inequalities. It is of interest

- A. to obtain a small gain theorem and construct an ISS-Lyapunov function satisfying a dissipation inequality of the interconnected system.

It is practically appealing if the ISS-Lyapunov function is smooth, i.e., continuously differentiable. This paper will make an essential step in this direction. Namely,

1. for general ISS systems, we derive a small gain condition and construct a Lipschitz continuous ISS-Lyapunov function;
2. for a special class of dissipation inequalities, we derive a small gain condition and construct a smooth ISS-Lyapunov function;
3. for general ISS systems, we derive a geometrical condition under which a smooth ISS-Lyapunov function can be constructed.

The paper is organized as follows. The ensuing section introduces necessary notations and gives a statement of the problem. Section 3 explains the main idea of our approach by using the simpler case of linear supply rate functions. In this linear case, the result follows from an application of the Perron-Frobenius theorem. The main results are presented in Section 4 for the nonlinear case. Two types of geometrical conditions are proposed to construct smooth ISS-Lyapunov functions as well as non-smooth ones. They are related to small gain conditions and previous results developed for the implication form. We draw conclusions and outline directions of future work in Section 5.

## 2 Interconnection in dissipative form

We use the following notation.  $(\cdot)^T$  denotes the transposition of a vector. For any vectors  $a, b \in \mathbb{R}^n$  the relation  $a \geq b$  is defined by  $a_i \geq b_i$  for all  $i = 1, \dots, n$ .

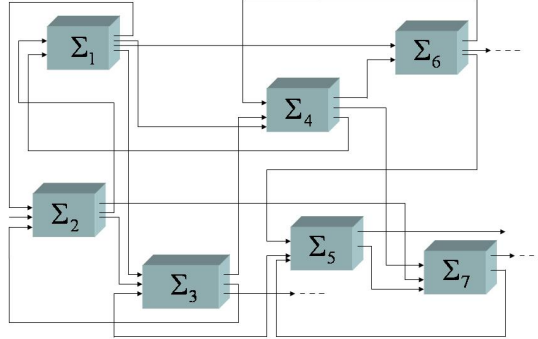

Figure 1: An interconnection  $\Sigma$

The relations  $>, \leq, <$  for vectors are defined in the same manner. That is, we are using the partial order on  $\mathbb{R}^n$  induced by the positive orthant  $\mathbb{R}_+^n$ . The negation of  $a \geq b$  is denoted by  $a \not\geq b$  and this means that there exists an  $i \in \{1, \dots, n\}$  such that  $a_i < b_i$ . By  $a \cdot b$  we denote the scalar product of two vectors and by  $A \circ B$  we denote the composition of operators  $A$  and  $B$ . To use standard formulations of input-to-state stability, we recall, that a function  $\alpha: [0, \infty) \rightarrow [0, \infty)$  is said to be of class  $\mathcal{K}$ , if  $\alpha$  is continuous,  $\alpha(0) = 0$  and  $\alpha$  is strictly increasing, if in addition it is unbounded, we say it is of class  $\mathcal{K}_\infty$ . A continuous function  $\alpha: [0, \infty) \rightarrow [0, \infty)$  is called positive definite if  $\alpha(x) = 0$  if and only if  $x = 0$ .

Consider a finite set of interconnected systems with state  $x = (x_1^T, \dots, x_n^T)^T$ , where  $x_i \in \mathbb{R}^{N_i}$ ,  $i = 1, \dots, n$  and  $N := \sum N_i$ . For  $i = 1, \dots, n$  the dynamics of the  $i$ -th subsystem is given by

$$\Sigma_i: \dot{x}_i = f_i(x_1, \dots, x_n, u), \quad (1)$$

where  $x \in \mathbb{R}^N$ ,  $u \in \mathbb{R}^M$ ,  $f_i: \mathbb{R}^{N+M} \rightarrow \mathbb{R}^{N_i}$ . For each  $i$  we assume unique existence of solutions and forward completeness of  $\Sigma_i$  in the following sense. If we interpret the variables  $x_j$ ,  $j \neq i$ , and  $u$  as unrestricted inputs, then system (1) is assumed to have a unique solution defined on  $[0, \infty)$  for any given initial condition  $x_i(0) \in \mathbb{R}^{N_i}$  and any  $L^\infty$ -inputs  $x_j: [0, \infty) \rightarrow \mathbb{R}^{N_j}$ ,  $j \neq i$ , and  $u: [0, \infty) \rightarrow \mathbb{R}^M$ . This can be guaranteed for instance by suitable Lipschitz conditions on the  $f_i$ . It will be no restriction to assume that all systems have the same (augmented) external input  $u$ . This interconnection can be depicted as a network or a graph, see Figure 1. We write the interconnection of the subsystems (1) as

$$\Sigma: \dot{x} = f(x, u), \quad (2)$$

where  $f = (f_1^T, \dots, f_n^T)^T: \mathbb{R}^{N+M} \rightarrow \mathbb{R}^N$ . We assume that each of the subsystems in (1) satisfies an ISS condition in the dissipative formulation, i.e., there are Lyapunov functions  $V_i: \mathbb{R}^{N_i} \rightarrow \mathbb{R}_+$  and functions  $\alpha_i, \gamma_{iu} \in \mathcal{K}_\infty$  and

$\gamma_{ij} \in \mathcal{K}_\infty \cup \{0\}$ ,  $i, j = 1, \dots, n$  such that

$$\dot{V}_i(x_i) \leq -\alpha_i(V_i(x_i)) + \sum_{i \neq j} \gamma_{ij}(V(x_j)) + \gamma_{iu}(\|u\|) \quad (3)$$

for all  $x_i \in \mathbb{R}^{N_i}$ ,  $i = 1, \dots, n$  and all  $u \in \mathbb{R}^M$ . The right hand side in (3) consisting of the functions  $\alpha_i$ ,  $\gamma_{iu}$  and  $\gamma_{ij}$  is called the supply rate of the dissipation inequality. In the sequel we will always assume that  $\gamma_{ii} \equiv 0$ . We will also assume that the Lyapunov functions  $V_i$  as well as the functions  $\alpha_i$  are continuously differentiable, which poses no real restriction.

As in one of our constructions we end up with a locally Lipschitz continuous Lyapunov function for the whole system (2), we note that in case that the  $V_i$  are only locally Lipschitz continuous, then it is sufficient to let (3) hold almost everywhere to characterize input-to-state stability.

Note that if in (3) we only require that  $\alpha_i$  is an element of the larger set of positive definite functions, then the  $i$ -th system is integral input-to-state stable (iISS) [23]. The set of iISS systems is essentially larger than the set of ISS systems. In particular, in the iISS framework, results of a small gain type and a corresponding Lyapunov construction were developed for  $n = 2$  in [10, 12].

The aim of this paper is to find conditions on the data of the dissipation inequalities (3) that guarantee ISS of the interconnected system (2) and to provide a construction of an ISS-Lyapunov function for the interconnection under these conditions. We will also discuss how an iISS result can be obtained in this way for a special class of systems.

### 3 The linear case

We begin by studying the linear case, because here the conditions are much easier to analyze and it gives an idea how the general procedure should work, even though for practical applications the linearity assumption is very often much too restrictive.

We assume that the ISS-Lyapunov formulation is given in a linear form. Here linear means, that the functions  $\alpha_i, \gamma_{iu} \in \mathcal{K}_\infty$  and  $\gamma_{ij} \in \mathcal{K}_\infty \cup \{0\}$   $i, j = 1, \dots, n$  are linear. Thus let  $a_i > 0, c_{ij} \in [0, \infty)$  be positive resp. nonnegative numbers which represent the corresponding linear functions. Define the matrices

$$A := \text{diag}(a_1, \dots, a_n), \quad \Gamma := (c_{ij})_{i,j=1,\dots,n} \quad (4)$$

and the vectors

$$\begin{aligned} \dot{V}_{vec}(x) &:= (\dot{V}_1(x_1) \quad \dots \quad \dot{V}_n(x_n))^T, \\ V_{vec}(x) &:= (V_1(x_1) \quad \dots \quad V_n(x_n))^T. \end{aligned} \quad (5)$$

Then the inequalities (3) can be compactly written as

$$\dot{V}_{vec}(x) \leq (-A + \Gamma)V_{vec}(x) + \gamma_u(\|u\|)$$

with the obvious definition of  $\gamma_u$ . In the previous equation  $\leq$  is to be interpreted componentwise as defined in the preliminaries. We note that  $(-A + \Gamma)$  is a Metzler matrix, thus a matrix for which Perron-Frobenius type results are available. An overall Lyapunov function can be defined using the following lemma.

**Lemma 3.1** Consider the matrices  $A$  and  $\Gamma$  defined in (4). There exists a vector  $\mu \in \mathbb{R}_+^n$ ,  $\mu > 0$  such that

$$\mu^T(-A + \Gamma) < 0 \quad (6)$$

if and only if the following spectral radius condition holds

$$r(A^{-1}\Gamma) < 1. \quad (7)$$

**Proof 3.2** Note that  $A = A^T$  as it is of diagonal form and  $A$  is invertible, because in (3) the functions  $\alpha_i \in \mathcal{K}_\infty$ ,  $i = 1, \dots, n$ . Define  $\eta := A\mu$ , so that  $\mu^T = \eta^T A^{-1}$ . Then  $\mu^T(-A + \Gamma) < 0$  is equivalent to

$$0 > \eta^T A^{-1}(-A + \Gamma) = \eta^T(-I + A^{-1}\Gamma).$$

If  $r(A^{-1}\Gamma) < 1$ , then by the Perron-Frobenius theorem there exists a vector  $\eta > 0$  such that

$$\eta^T(A^{-1}\Gamma) < \eta^T$$

or equivalently  $\eta^T(-I + A^{-1}\Gamma) < 0$ , as desired. Conversely, if  $r(A^{-1}\Gamma) \geq 1$  then there exists a vector  $z \geq 0, z \neq 0$  such that

$$(A^{-1}\Gamma - I)z \geq 0.$$

We now fix such a vector  $z$ . So for any  $\eta > 0$  we have

$$\eta^T(A^{-1}\Gamma - I)z \geq 0$$

so that it cannot hold that  $\eta^T(-I + A^{-1}\Gamma) < 0$ .

We now assume that  $r(A^{-1}\Gamma) < 1$  and choose a vector  $\mu \in \mathbb{R}_+^n$ ,  $\mu > 0$  such that (6) holds. Consider the following candidate for an ISS-Lyapunov function

$$V(x) := \mu^T V_{vec}(x) = \sum_{i=1}^n \mu_i V_i(x_i). \quad (8)$$

Then we have

$$\dot{V}(x) = \mu^T \dot{V}_{vec}(x) \leq \mu^T(-A + \Gamma)V_{vec}(x) + \mu^T \gamma_u(\|u\|)$$

and defining  $0 > L := \mu^T(-A + \Gamma)$  we obtain

$$\dot{V}(x) \leq LV_{vec}(x) + \mu^T \gamma_u(\|u\|) \leq -lV(x) + \mu^T \gamma_u(\|u\|) \quad (9)$$

for a positive number defined by  $l := -\max_i \frac{L_i}{\mu_i}$ . Note that if  $\Gamma$  is irreducible, then  $\mu > 0$  may be chosen as a left eigenvector of  $(-A + \Gamma)$  corresponding to the largest eigenvalue, which is real and negative by the Perron Frobenius theorem. In this case  $l$  is this largest eigenvalue. The last equation (9) is a dissipation inequality for the whole interconnection (2), and in (8) we have obtained a smooth ISS-Lyapunov function  $V(x)$ . We have thus proved the following.

**Proposition 3.3** Consider the interconnected system (1), where each of the subsystems satisfies an ISS condition of the form (3) with linear  $\alpha_i, \gamma_{ij}$ . If for the matrices  $A, \Gamma$  defined in (4) we have (7), then the interconnected system (2) is ISS with a ISS Lyapunov function given by (8).

Since  $A^{-1}\Gamma$  is the gain matrix of the  $n$  ISS systems, the spectral radius condition (7) agrees with the linear case of the small gain condition developed in [5, 4, 7]. In the next section we will see how this idea can be used in the general nonlinear case.

The development in this section conforms to the classical result [1] for a special case concerned with global asymptotic stability.

## 4 Main results

Unfortunately, there is no immediate extension of the construction in the previous section to the general nonlinear case. For example the matrices  $A$  and  $\Gamma$  contain nonlinear functions instead of numbers and the notions of eigenvalue and spectral radius are no longer available. The construction problem of an ISS-Lyapunov function becomes more difficult. This section first shows a sufficient condition under which the extension to the general nonlinear case is possible. The resulting ISS-Lyapunov function is, thereby, smooth. Next, since the computation of the sufficient condition is generally hard, we show an explicit construction for an ISS-Lyapunov function in a special case. For the general nonlinear case, we will provide a non-smooth construction.

### 4.1 Smooth construction

The aim of this subsection is to construct smooth Lyapunov functions, which can be important in implementation. We consider the interconnected system (2) and assume that the subsystems (1) are ISS with the ISS-Lyapunov functions  $V_i$  satisfying (3) where the supply rate functions can be nonlinear.

First let us note that the condition (7) can be equivalently formulated as  $r(\Gamma A^{-1}) < 1$  or written as

$$\Gamma A^{-1}s \not\geq s, \quad \forall s \in \mathbb{R}_+^n \setminus \{0\}. \quad (10)$$

The last condition makes sense also for nonlinear operators defined below. The data we are working with is defined in (3). We assume from now on that the matrix

$$\Gamma := (\gamma_{ij})_{i,j=1,\dots,n} \in (\mathcal{K}_\infty \cup \{0\})^{n \times n}$$

is irreducible and similarly to the linear case we define the following map  $\Gamma : \mathbb{R}_+^n \rightarrow \mathbb{R}_+^n$  by

$$\Gamma(s) = \left( \sum_{j=1}^n \gamma_{1j}(s_j), \dots, \sum_{j=1}^n \gamma_{nj}(s_j) \right)^T, \quad s \in \mathbb{R}_+^n \quad (11)$$

and a diagonal operator  $A : \mathbb{R}_+^n \rightarrow \mathbb{R}_+^n$  by

$$A(s) := (\alpha_1(s_1) \quad \dots \quad \alpha_n(s_n))^T \in \mathbb{R}_+^n. \quad (12)$$

With this notation, the inequalities (3) can be written in a vector form

$$\dot{V}_{vec} \leq (-A + \Gamma)(V_{vec}(x)) + \gamma_u(\|u\|) \quad (13)$$

with  $\gamma_u$  defined in the obvious way.

We now reformulate the small gain conditions that were introduced in [5, 7, 18] to make them suitable for the dissipative formulation. The nonrobust version of the small gain condition is given by

$$\Gamma \circ A^{-1}(s) \not\geq s, \quad \forall s \in \mathbb{R}_+^n \setminus \{0\}. \quad (14)$$

which is seemingly a nonlinear generalization of (10). However, it has been shown in [5, 12] that this condition is not quite sufficient to obtain desired robustness with respect to the external input. Thus, the condition we now want to impose is the *robust small gain condition* which requires that for some  $D = \text{diag}(\text{id} + \beta_1, \dots, \text{id} + \beta_n)$ ,  $\beta_i \in \mathcal{K}_\infty$  we have

$$D \circ \Gamma \circ A^{-1}(s) \not\geq s, \quad \forall s \in \mathbb{R}_+^n \setminus \{0\}. \quad (15)$$

To compare this with the linear case, note that in the linear case both (14) and (15) are equivalent to  $r(\Gamma A^{-1}) < 1$  which is in turn equivalent to the condition  $r(A^{-1}\Gamma) < 1$ . In this sense, the property (15) is a natural generalization of the linear small gain condition (10).

One of the central results of [7, 18], [6] for the implication form of ISS systems is that, in the case that  $\Gamma$  is irreducible and (15) holds, there exists a continuously differentiable path  $\sigma : \mathbb{R}_+ \rightarrow \mathbb{R}_+^n$  such that  $\sigma(0) = 0$ ,  $\sigma$  is strictly increasing and unbounded in every component and so that

$$D \circ \Gamma \circ A^{-1}(\sigma(\tau)) < \sigma(\tau), \quad \forall \tau > 0. \quad (16)$$

The next subsection will show that the existence of such a path can also play a central role in the construction for a non-smooth ISS-Lyapunov function even in the dissipative formulation.

Since this subsection pursues a smooth ISS-Lyapunov function by extending the idea presented in the previous section, we consider the assumption that there are bounded positive definite functions  $\eta_i, i = 1, \dots, n$ , such that  $\int_0^\infty \eta_i(\alpha_i(\tau)) d\tau = \infty$  and so that for  $\eta = (\eta_1, \dots, \eta_n)^T$  we have

$$\eta(s)^T \Gamma \circ A^{-1}(s) < \eta(s)^T s, \quad \forall s \in \mathbb{R}_+^n \setminus \{0\}. \quad (17)$$

Again a robust version of this condition is that there exists a diagonal  $D$  as before such that

$$\eta(s)^T D \circ \Gamma \circ A^{-1}(s) < \eta(s)^T s, \quad \forall s \in \mathbb{R}_+^n \setminus \{0\}. \quad (18)$$

The following result shows that both these geometrical conditions lead to the construction of interesting smooth Lyapunov functions.

**Theorem 4.1** *Consider the interconnected systems (1) and assume that each subsystem has a dissipative ISS-Lyapunov function as in (3). Then*

(i) *If the weak small gain condition (17) is satisfied and if for each  $i \in \{1, \dots, n\}$  and  $\lambda_i(\tau) := \eta_i(\alpha_i(\tau)), \tau \in \mathbb{R}_+$  we have*

$$\int_0^\infty \lambda_i(\tau) d\tau = \infty, \quad (19)$$

*then the interconnection (2) is iISS with an iISS-Lyapunov function defined by*

$$V(x) := \sum_{i=1}^n \int_0^{V_i(x_i)} \lambda_i(\tau) d\tau. \quad (20)$$

(ii) If the robust small gain condition (18) is satisfied and

$$\liminf_{\tau \rightarrow \infty} \lambda_i(\tau) > 0 \quad (21)$$

holds, then the interconnection (2) is ISS with a Lyapunov function  $V(x)$  again defined by (20).

**Proof 4.2** First note that (19) guarantees that the function  $V$  defined in (20) is a proper function.

(i) Consider the derivative of  $V$  along the trajectories of the system (2). Defining  $\lambda(V_{vec}) := (\lambda_1(V_1), \dots, \lambda_n(V_n))^T$  and using (13) we obtain

$$\begin{aligned} \frac{dV}{dt} &= \lambda(V_{vec})^T \dot{V}_{vec} \\ &< \lambda(V_{vec})^T (-A(V_{vec}) + \Gamma(V_{vec}) + \gamma_u(\|u\|)) \end{aligned} \quad (22)$$

From assumption (17) we have for all  $x \neq 0$

$$\eta(A(V_{vec}))^T \Gamma \circ A^{-1} \circ A(V_{vec}) < \eta(A(V_{vec}))^T A(V_{vec})$$

and thus

$$-\lambda(V_{vec})^T A(V_{vec}) + \lambda(V_{vec})^T \Gamma(V_{vec}) < 0. \quad (23)$$

Using the properness of  $V$  defined in (20), this term can be bounded from above by  $-\alpha(V)$  for some positive definite function  $\alpha$ . Further recall that the functions  $\eta_i$  are assumed to be bounded. Hence  $\lambda_i$ ,  $i = 1, \dots, n$  is also bounded and there exists some function  $\gamma \in \mathcal{K}_\infty$  such that  $\lambda^T(V_{vec}) \cdot \gamma_u(\|u\|) \leq \gamma(\|u\|)$ . From (22) it follows that

$$\frac{dV(x)}{dt} \leq -\alpha(V(x)) + \gamma(\|u\|) \quad (24)$$

and the *i*ISS property of the interconnection follows.

(ii) Note that (21) implies (19). In case the stronger assumption (18) holds, instead of (23) we obtain

$$\begin{aligned} &-\lambda(V_{vec})^T A(V_{vec}) + \lambda(V_{vec})^T \Gamma(V_{vec}) \\ &< -\lambda(V_{vec})^T (D - \text{id}) \circ \Gamma(V_{vec}) \end{aligned}$$

for all  $x \neq 0$ . Let  $\Gamma_{*k} \neq 0$  denote the  $k$ -th column of  $\Gamma$ . When  $\Gamma_{*k} \neq 0$  holds for all  $k = 1, 2, \dots, n$ , using the definition of  $D$  in the above inequality verifies that an upper bound of the form  $-\alpha(V)$  can be obtained for some  $\alpha \in \mathcal{K}_\infty$  to be used in (24). To address the case where  $\Gamma_{*k} = 0$  holds for an integer  $k \in \{1, 2, \dots, n\}$ , define  $s_{\bar{k}} : \mathbb{R}_+^{n-1}$  and  $\eta_{\bar{k}} : \mathbb{R}_+^{n-1} \rightarrow \mathbb{R}_+^{n-1}$  by removing the  $k$ -th components from  $s$  and  $\eta$ , respectively. Define  $V_{vec, \bar{k}}$  and  $\lambda_{\bar{k}}$  in the same manner. The operators which remove the  $k$ -th columns and the  $k$ -th rows from  $D$ ,  $\Gamma$  and  $A$  are denoted by  $D_{\bar{k}\bar{k}}$ ,  $\Gamma_{\bar{k}\bar{k}}$  and  $A_{\bar{k}\bar{k}}$ , respectively. Evaluating both sides of (18) for  $s_k = 0$  carefully, we can verify that, if  $\Gamma_{*k} = 0$  holds, the assumption (18) implies

$$\begin{aligned} &\eta(s)^T D \circ \Gamma \circ A^{-1}(s) \\ &= \eta_{\bar{k}}(s_{\bar{k}})^T D_{\bar{k}\bar{k}} \circ \Gamma_{\bar{k}\bar{k}} \circ A_{\bar{k}\bar{k}}^{-1}(s_{\bar{k}}) < \eta_{\bar{k}}(s_{\bar{k}})^T s_{\bar{k}}, \\ &\quad \forall s \in \mathbb{R}_+^n \setminus \{s : s_{\bar{k}} \neq 0\}. \end{aligned}$$



Hence, we obtain

$$\begin{aligned} & -\lambda(V_{vec})^T A(V_{vec}) + \lambda(V_{vec})^T \Gamma(V_{vec}) \\ & < -\lambda_k(V_k) \alpha_k(V_k) - \lambda_{\bar{k}}(V_{vec, \bar{k}})^T (D_{\bar{k}} - \text{id}) \circ \Gamma_{\bar{k}}(V_{vec, \bar{k}}) \end{aligned}$$

in the case of  $\Gamma_{*k} = 0$ . Thus, when  $\Gamma_{*j} \neq 0$  holds for all  $j \neq k$ , the inequality (24) with some  $\alpha \in \mathcal{K}_\infty$  follows from (22), (21) and the boundedness of  $\eta_i$ . The above technique also applies to the cases where  $\Gamma_{*k} = 0$  holds for multiple  $k$ 's.

Therefore in case of (18) and (21) the overall system is ISS. (If one wants to try a simpler argument, it would be worth replacing  $\Gamma_{*k} = 0$  by sufficiently small  $\Gamma_{*k} \neq 0$  maintaining (18).)

The function  $V$  in (20) is smooth, i.e., continuously differentiable, which is a desirable property, in general. Note that the irreducibility of  $\Gamma$  was not used in the proof, i.e., Theorem 4.1 holds for arbitrary type of interconnection.

**Remark 4.3** Theorem 4.1 reduces the problem of a construction of a Lyapunov function to a geometrical problem of the construction of a continuous curve in  $\mathbb{R}_+^n$  parameterized by  $\eta_i$  and satisfying (17) or respectively (18). However, the existence and construction of such auxiliary functions  $\eta_i$  may be a nontrivial problem. We hope that the small gain condition (15) implies the existence. An explicit construction of  $\eta$  is a matter of our future research. For ISS systems supplied with the implication type characterization, the results in [4] and [7] show that the small gain condition (15) implies the existence of the path  $\sigma$  described in (16) by using the Knaster-Kuratowski-Mazurkiewicz theorem. We suspect that using complementary arguments (18) can be shown. It is worth noting that, in the linear case,  $r(A^{-1}\Gamma) < 1$  is equivalent to (16) as well as to (18). The latter equivalence has been shown in Lemma 3.1. The former equivalence is obtained by studying right eigenvectors, while the latter uses left eigenvectors. Although the generalization of those eigenvectors is nontrivial, it may be natural to conjecture that (15) does not only imply (16) but also (18) even for the nonlinear case. Subsection 4.3 will show that this conjecture holds true in a special case.

**Remark 4.4** In the case of  $n = 2$ , the problems (17) and (18) are solved and the construction of the auxiliary functions  $\eta_i(s) = \lambda_i(\alpha_i^{-1}(s))$  is shown explicitly in [12, 10], where the small gain condition (15) implies the existence when  $n = 2$ .

## 4.2 Non-smooth construction

In the following, we provide a non-smooth construction of an ISS-Lyapunov function for the interconnection (2) where a corresponding auxiliary function  $\sigma$  can be explicitly constructed.

**Theorem 4.5** *Let the systems given in (1) be ISS in the sense of (3) and assume that their supply rate functions are such that the operators  $A$  and  $\Gamma$  defined above satisfy the robust small gain condition (15). Assume further that for  $\sigma_1, \dots, \sigma_n$  given in (16) there are constants  $0 < c < C$  such that*

$$0 < c < \frac{d}{d\tau} \sigma_i^{-1} \circ \alpha_i(\tau) < C, \quad \text{for all } \tau > 0.$$

Then the interconnection (2) is ISS. An ISS-Lyapunov function is given by

$$V(x) := \max_{i=1, \dots, n} \sigma_i^{-1} \circ \alpha_i(V_i(x_i)). \quad (25)$$

**Proof 4.6** Let us assume for the moment that for a given  $x \neq 0$  we have that the maximum in (25) is uniquely attained in the first component  $i = 1$ , i.e.,  $V(x) = \sigma_1^{-1} \circ \alpha_1(V_1(x_1))$ . Denote by  $\Gamma_1$  the first row of  $\Gamma$ . We obtain

$$\dot{V}(x) = \frac{d}{dt} \sigma_1^{-1} \circ \alpha_1(V_1(x_1)) = (\sigma_1^{-1} \circ \alpha_1)'(V_1(x_1)) \dot{V}_1(x_1)$$

and

$$\dot{V}_1(x_1) \leq [-\alpha_1(V_1(x_1)) + \Gamma_1(V_{vec}(x)) + \gamma_{1u}(\|u\|)]$$

We now denote  $z_i = \alpha_i(V_i(x_i))$ ,  $z := (z_1, \dots, z_n)^T$  and obtain the following representation

$$\begin{aligned} -\alpha_1(V_1(x_1)) + \Gamma_1(V_{vec}(x)) &= -z_1 + \Gamma_1 \circ A^{-1}(z) \\ &= -\sigma_1 \circ \sigma_1^{-1}(z_1) + \Gamma_1 \circ A^{-1}(\sigma_1 \circ \sigma_1^{-1}(z_1), \dots, \sigma_n \circ \sigma_n^{-1}(z_n)). \end{aligned}$$

By the assumption of this first part of the proof we have  $\sigma_1^{-1}(z_1) > \sigma_j^{-1}(z_j)$  for  $j = 2, \dots, n$ , and so we obtain

$$-z_1 + \Gamma_1 \circ A^{-1}(z) \leq -\sigma_1 \circ \sigma_1^{-1}(z_1) + \Gamma_1 \circ A^{-1} \circ \sigma(\sigma_1^{-1}(z_1)) \quad (26)$$

Now for  $\tau := \sigma_1^{-1}(z_1)$  we have by (16)

$$D \circ \Gamma \circ A^{-1} \circ \sigma(\tau) \leq \sigma(\tau)$$

hence

$$\Gamma \circ A^{-1} \circ \sigma(\tau) \leq D^{-1} \circ \sigma(\tau)$$

and so (recall that  $\beta_i$  is defined before (15)) we have from (26) for the first component that

$$\begin{aligned} &-\sigma_1(\tau) + \Gamma_1 \circ A^{-1} \circ \sigma(\tau) \\ &< ((\text{id} + \beta_1)^{-1} - \text{id}) \circ \sigma_1(\tau) \\ &= -\beta_1 \circ (\text{id} + \beta_1)^{-1} \circ \alpha_1(V_1(x_1)) < 0. \end{aligned} \quad (27)$$

Hence under the assumption that  $V(x) = \sigma_1^{-1} \circ \alpha_1(V_1(x_1))$  is uniquely given we obtain

$$\dot{V}(x) \leq -c\beta_1 \circ (\text{id} + \beta_1)^{-1} \circ \sigma_1(V(x)) + C\gamma_{1u}(\|u\|).$$

The argument can be repeated for the indices  $i = 2, \dots, n$  in the same manner and so setting

$$\tilde{\alpha}(s) := \min_{i=1, \dots, n} c\beta_i \circ (\text{id} + \beta_i)^{-1} \circ \sigma_i(s)$$

and

$$\gamma(s) := \max_{i=1, \dots, n} C\gamma_{iu}(s)$$

we obtain that

$$\dot{V}(x) \leq -\tilde{\alpha}(V(x)) + \gamma(\|u\|)$$

for all points  $x \in \mathbb{R}^N$  where the maximizing argument in (25) is uniquely defined. As the set of such points is an open and dense subset of  $\mathbb{R}^N$  and as the function  $V$  is locally Lipschitz continuous, we can prove that  $V$  is a Lipschitz ISS Lyapunov function for the interconnection [3],[2], [7]. This assertion can be confirmed easily as follows: Since  $V$  is obtained by the maximization of  $\mathcal{C}^1$  functions  $V_i$ ,  $i = 1, 2, \dots, n$ , the Clarke subgradient of  $V$  in  $x \in \mathbb{R}^n$  can be computed by the set

$$\partial_{Cl}V(x) = \text{conv} \left\{ \begin{array}{l} \nabla (\sigma_i^{-1} \circ \alpha_i \circ V_i)(x_i) \mid \\ \sigma_i^{-1} \circ \alpha_i(V_i(x_i)) = V(x) \end{array} \right\},$$

where  $\text{conv } M$  denotes the convex hull of the set  $M$ . As we have the dissipation inequality presented above as  $\dot{V} \leq -\tilde{\alpha}(V(x)) + \gamma(\|u\|)$  for each of the extremal points of  $\partial_{Cl}V(x)$ , the dissipation inequality holds in terms of the Clarke generalized derivative for each  $\zeta$  in the Clarke subgradient.

Interestingly, Theorem 4.5 demonstrates that the dissipative formulation results in the same small gain condition (15) as the implication formulation if we use the non-smooth Lyapunov function of the form (25).

For ISS systems given in terms of dissipation inequalities, we have obtained two different ways of constructing ISS Lyapunov functions in this paper. One is smooth, while the other is non-smooth. To compare the two constructions, we briefly return to the linear case as detailed in Section 3. Recall that for the matrices in (4), the required condition is  $r(A^{-1}\Gamma) < 1$ . The construction explained in Section 3 uses a left vector  $\mu \in \mathbb{R}_+^n$  such that  $\mu^T(-A + \Gamma) < 0$  and sets  $V(x) := \mu^T V_{vec}(x)$ . In the construction of Theorem 4.5 we choose a right vector  $s \in \mathbb{R}_+^n$  such that  $\Gamma A^{-1}s < s$ . For  $\mu := A^{-1}s$  this is equivalent to  $(-A + \Gamma)\mu < 0$ . We then let  $V(x) := \max_{i=1, \dots, n} \mu_i^{-1} V_i(x_i)$  and by Theorem 4.5 this is an ISS Lyapunov function. In the context of convex analysis maximization and summation are dual operations. In this sense the two constructions are dual to one another.

### 4.3 Linearly Scaled Gains

In this subsection we specialize the smooth result obtained in Subsection 4.1 to the case where the supply rates are given by linearly scaling gain functions associated with each of the subsystems.

To be precise, we assume that there exist positive definite functions  $g_i$  and constants  $a_i, c_{ij} \in \mathbb{R}_+$ ,  $a_i > 0$ ,  $i, j = 1, \dots, n$  such that the gain functions in (3) are given by

$$\gamma_{ij}(s) = c_{ij}g_j(s), \quad \forall j, \quad \alpha_i(s) = a_i g_i(s), \quad \forall i. \quad (28)$$

We now let  $\tilde{A} = \text{diag}(a_1, \dots, a_n)$  and  $\tilde{C} = (c_{ij})_{i,j=1, \dots, n}$  and we denote for  $s \in \mathbb{R}_+^n$

$$g(s) := (g_1(s_1), \dots, g_n(s_n))^T.$$

Note that with respect to our previous notation we have

$$A(s) = \tilde{A}g(s), \quad \Gamma(s) = \tilde{C}g(s). \quad (29)$$

Note also that from (3) we obtain ISS of the subsystems if we have  $g_i \in \mathcal{K}_\infty$ ,  $i = 1, \dots, n$ . On the other hand if the  $g_i$ 's are only positive definite, then we merely have iISS for the subsystems

**Theorem 4.7** Consider the interconnected systems (1) and assume that each subsystem has a function  $V_i(x_i)$  as in (3) where the gain functions satisfy (28). Assume  $r(\tilde{A}^{-1}\tilde{C}) < 1$  and let  $\mu > 0$  be a vector such that  $\mu^T(-\tilde{A} + \tilde{C}) < 0$ .

(i) If the functions  $g_i, i = 1, \dots, n$  are positive definite, then the interconnected system is iISS with an iISS Lyapunov function given by

$$V(x) := \mu^T V_{vec}(x). \quad (30)$$

(ii) If the functions  $g_i \in \mathcal{K}_\infty, i = 1, \dots, n$ , then the interconnected system is ISS with an ISS Lyapunov function given by (30).

**Proof 4.8** First note, that the choice of  $\mu$  in the formulation of the theorem is possible by Lemma 3.1. We have for  $V(x) := \mu^T V_{vec}(x)$  that

$$\dot{V}(x) = \mu^T \dot{V}_{vec}(x) \leq \mu^T(-\tilde{A} + \tilde{C})g(V_{vec}(x)) + \mu^T \gamma_u(\|u\|)$$

and defining  $0 > L := \mu^T(-\tilde{A} + \tilde{C})$  we obtain

$$\dot{V}(x) \leq Lg(V_{vec}(x)) + \mu^T \gamma_u(\|u\|) \leq -l(V(x)) + \mu^T \gamma_u(\|u\|),$$

where we define

$$l(s) := \min\{-Lg(V_{vec}(x)) \mid \mu^T V_{vec}(x) = s\}.$$

It is clear that  $l$  is positive definite if the  $g_i$ 's are and that  $l \in \mathcal{K}_\infty$  if the  $g_i$  are. This proves the assertion.

From (29), we can verify that  $r(\tilde{A}^{-1}\tilde{C}) < 1$  is equivalent to (15) when  $g_i \in \mathcal{K}_\infty$ , i.e., all subsystems are ISS. Therefore, the conjecture stated in Remark 4.3 is verified in this special class of nonlinear interconnected systems.

It is worth mentioning that the spectral radius condition  $r(\tilde{A}^{-1}\tilde{C}) < 1$  implicitly requires some subsystems in the overall system to be ISS in the case (i) of the above theorem. For instance, in the two subsystems case,  $a_1 < c_{12}$  implies  $a_2 > c_{21}$  which indicates that at least one subsystem needs to be ISS although the subsystem is defined by a dissipation inequality only with positive definite functions of the iISS type. This fact is consistent with the result in [11].

## 5 Concluding remarks

In this paper we have pursued the construction of Lyapunov functions for nonlinear ISS systems interconnected in a general way, and introduced a geometrical approach based on the existence of some auxiliary functions. We assume that each system is given by a dissipation inequality of the ISS type, which contrasts with previous results on general interconnected systems supplied with the implication-type ISS characterization. With the help of the dissipative characterization, this paper has proposed two formulations whose solutions, i.e., auxiliary functions, explicitly provide us with smooth and non-smooth Lyapunov functions, respectively, of the interconnected system. For the non-smooth construction, the auxiliary function can be found explicitly. The existence condition has been related to a generalized small gain condition. For the smooth

construction, we have shown how the auxiliary function can be found explicitly in a special case of supply rate functions. Although computing the auxiliary function for general supply rates is a matter of future investigations, the special case indicates that the smooth formulation has potential for dealing with iISS systems. We have also discussed an existence condition for the auxiliary function in the smooth construction. As in Remark 4.3, its small gain type interpretation is only a conjecture which needs to be investigated further although the conjecture holds true in a special case of supply rates. We also hope to relax the technical assumption  $0 < c < (\sigma_i \circ \alpha_i)'(\tau) < C$  in Theorem 4.5 for the non-smooth construction. Dealing with general networks of iISS systems along the lines of this paper is also an interesting topic of further study.

## References

- [1] M. Araki. Stability of large-scale nonlinear systems—quadratic-order theory of composite-system method using  $M$ -matrices. *IEEE Trans. Automatic Control*, AC-23(2):129–142, 1978.
- [2] F. H. Clarke. Nonsmooth analysis in control theory: a survey. *European J. Control*, 7:63–78, 2001.
- [3] F. H. Clarke, Yu. S. Ledyaev, R. J. Stern, and P. R. Wolenski. *Nonsmooth Analysis and Control Theory*. Springer-Verlag, Berlin, 1998.
- [4] S. Dashkovskiy, B. Rüffer, and F. Wirth. An ISS Lyapunov function for networks of ISS systems. In *Proc. 17th Int. Symp. Math. Theory of Networks and Systems, MTNS2006*, pages 77–82, Kyoto, Japan, July 24-28 2006.
- [5] S. Dashkovskiy, B. Rüffer, and F. Wirth. An ISS small-gain theorem for general networks. *Math. Control Signals Systems*, 19:93–122, 2007.
- [6] S. Dashkovskiy, B. Rüffer, and F. Wirth. Small gain theorems for large scale systems and construction of ISS Lyapunov functions. *SIAM J. Control Optim.*, 48(6):4089–4118, 2010.
- [7] S. Dashkovskiy, B. S. Rüffer, and F. R. Wirth. A Lyapunov ISS small gain theorem for strongly connected networks. In *Proc. 7th IFAC Symposium on Nonlinear Control Systems, NOLCOS2007*, pages 283–288, Pretoria, South Africa, August 2007.
- [8] D. J. Hill and P. J. Moylan. Stability results for nonlinear feedback systems. *Automatica*, 13:377–382, 1977.
- [9] H. Ito. A constructive proof of ISS small-gain theorem using generalized scaling. In *Proceedings of the 41st IEEE Conference on Decision and Control, 2002*, pages 2286–2291, Las Vegas, Nevada, USA, 2002.
- [10] H. Ito. State-dependent scaling problems and stability of interconnected iISS and ISS systems. *IEEE Trans. Automat. Control*, 51(10):1626–1643, 2006.

- [11] H. Ito and Z.-P. Jiang. Nonlinear small-gain condition covering iISS systems: Necessity and sufficiency from a Lyapunov perspective. In *The 45th IEEE Conf. Decision Control*, pages 355–360, 2006.
- [12] H. Ito and Z.-P. Jiang. Small-gain conditions and lyapunov functions applicable equally to iISS and ISS systems without uniformity assumption. In *2008 American Control Conference*, pages 2297–2303, 2008.
- [13] Z.-P. Jiang, I. M. Y. Mareels, and Y. Wang. A Lyapunov formulation of the nonlinear small-gain theorem for interconnected ISS systems. *Automatica J. IFAC*, 32(8):1211–1215, 1996.
- [14] Z.-P. Jiang, A. R. Teel, and L. Praly. Small-gain theorem for ISS systems and applications. *Math. Control Signals Systems*, 7:95–120, 1994.
- [15] Z.-P. Jiang and Y. Wang. A generalization of the small-gain theorem for large-scale complex systems. In *Proc. of the 2008 World Congress on Intelligent Control and Automation (WCICA)*, pages 1188–1193, Chongqing, China, June 25-27 2008.
- [16] I. Karafyllis and Z.-P. Jiang. A vector small-gain theorem for general nonlinear control systems. *submitted*, 2009. <http://arxiv.org/pdf/0904.0755v1>.
- [17] P. J. Moylan and D. J. Hill. Stability criteria for large-scale systems. *IEEE Trans. Automatic. Control*, 23:143–149, 1978.
- [18] B. S. Rüffer. *Monotone Systems, Graphs, and Stability of Large-Scale Interconnected Systems*. Dissertation, Fachbereich 3, Mathematik und Informatik, Universität Bremen, Germany, August 2007. Available online: <http://nbn-resolving.de/urn:nbn:de:gbv:46-diss000109058>.
- [19] B. S. Rüffer, C. M. Kellett, and S. R. Weller. Connection between cooperative positive systems and integral input-to-state stability of large-scale systems. *Automatica*, 46(6):1019–1027, 2010.
- [20] R. Sepulchre, M. Janković, and P. V. Kokotović. *Constructive nonlinear control*. Communications and Control Engineering Series. Springer-Verlag, Berlin, 1997.
- [21] E. D. Sontag. Smooth stabilization implies coprime factorization. *IEEE Trans. Automat. Control*, 34(4):435–443, 1989.
- [22] E. D. Sontag. On the input-to-state stability property. *European J. Control*, 1:24–36, 1995.
- [23] E. D. Sontag. Comments on integral variants of ISS. *Systems Control Lett.*, 34(1-2):93–100, 1998.
- [24] J. C. Willems. Dissipative dynamical systems. *Arch. Rational Mechanics and Analysis*, 45:321–393, 1972.